



SUSTAINABILITY REPORT 2024

Contents

2	Contents				
3	Foreword by the management				
4	Scope of reporting				
	GENERAL INFORMATION	6			
7	Our company profile				
7	Our family business				
8	Our core competencies				
8	Our customers				
9	Our products and solutions				
10	Our locations				
10	Location development 2024				
11	Our philosophy				
11	Our vision				
11	Our guiding principles				
12	Our stakeholder communication				
13	Our partners and suppliers				
14	Our staff				
16	Our governance				
17	Our risk management				
18	Our memberships				
19	Our economic performance				
20	Our innovations				
	ETHICAL BUSINESS	21			
22	Our Code of Conduct				
23	Our compliance				
24	Our whistleblowing system				
25	Our information security and data protection management system				
27	Our materials and waste management				
28	Our energy and water consumption				
30	Our greenhouse gas emissions				
31	Our fleet management				
32	Extract from our R&D activities				
	SOCIAL SUSTAINABILITY			33	
34	Our health and occupational safety				
36	Our training and further education				
37	An excerpt from our social commitment				
	GRI CONTENT INDEX			38	
	LEGAL NOTICE			42	

Preliminary remark:

For reasons of linguistic simplicity, the masculine form is used in this document, but all genders are meant equally. We respect and recognize the diversity of gender identities and use this spelling for practical reasons only.

Foreword by the management



Paulo Cruz Pinto,
Managing Director



André Blech,
Managing Director

Dear Readers,

For Meleghy Automotive, the past year 2024 was characterized by important decisions on the path to greater sustainability and climate neutrality. In a dynamic and challenging environment in the automotive industry, we have positioned ourselves clearly: responsible action and sustainable business practices are not a side issue for us - they are firmly anchored at the core of our corporate strategy.

Our development in the past year is based on three central areas of action: Climate protection, resource conservation and social responsibility. Together with our committed employees and reliable partners, we took concrete steps - including reducing our CO₂ emissions, increasing the use of renewable energies at our sites and optimizing processes to use resources more efficiently.

These measures make a significant contribution to reducing our ecological footprint and to the sustainable orientation of our production processes.

A particular focus in 2024 was again on cooperation with our partners along the supply chain. Together

with customers and suppliers, we are developing future-oriented solutions - for lighter, more efficient and more environmentally friendly mobility.

Despite all the challenges of the past year, we are convinced that sustainable corporate governance is the key to long-term success. With this report, we would like to show you our progress and reaffirm our clear commitment to a responsible future.

Our sincere thanks go to all employees who have made this development possible with their dedication, expertise and daily commitment.

Let's shape a sustainable future together.

Forming tomorrow. For you. For us. For everyone.

With best regards

Paulo Cruz Pinto | André Blech
Management der Meleghy Automotive

Scope of reporting

Meleghy Automotive's Sustainability Report 2024 provides a comprehensive insight into our strategy, goals and achievements in the area of sustainability.

In this report, we analyze our commitment in various areas of sustainability, including economic, environmental and social sustainability. We take into account our main markets, the expectations of our stakeholders, applicable legislation and organizational requirements.

We examine our products and services as well as key ethical, social, ecological and corporate policy aspects that significantly influence our actions and our environment.

Through efficient processes and a continuous willingness to improve, we strengthen our credibility and acceptance as a reliable key supplier for our customers. We closely monitor the evolving regula-

tion of the competitive environment, including the current Supply Chain Act and the CSRD Directive, and adapt flexibly to maintain our competitiveness. We are also integrating the sustainable priorities set by the current federal government at an early stage in order to respond effectively to the increasing legalization of corporate responsibility. Some of the data presented in this report is also included in the annual report of the Meleghy International group of companies and is audited externally.

Our sustainability reporting is based on the standards of the GRI (Global Reporting Initiative) and the 17 Sustainable Development Goals (SDGs) of the United Nations (UN). Based on a comprehensive materiality analysis and an employee survey, we have identified five SDGs on which we have the greatest influence and which are therefore particularly relevant to us.



Focus on SDGs 2024



REPORTING PERIOD, SCOPE AND REPORTING CYCLE

This sustainability report, prepared in accordance with the GRI standard, contains measures, results and key figures for the period from January 1, 2024 to December 31, 2024 and thus covers the business activities of all productive Meleghy Automotive companies in the 2024 financial year. The sustainability report is updated annually and published on the Meleghy Automotive website.

All disclosures in this report relate to the sustainability-related business activities of all companies operating under the Meleghy Automotive business unit. The business unit is part of the Meleghy International Group, operating under the name Meleghy & Cie. Automotive GmbH. No information, valuations or material topics relating to minority interests and investments have been included in the report. The report does not include companies, joint ventures and the like that belong to the Meleghy International group of companies but are not allocated to the Meleghy Automotive division. These include PDahlke Engineering GmbH and Innomotive Safety Systems GmbH. We refrain from naming the individual legal

names of the Meleghy Automotive companies in the sustainability report and refer to individual locations or generally speak of the Meleghy Automotive division in relation to all companies.

SIGNIFICANT CHANGES IN THE ORGANIZATION

In 2024, the succession process initiated in the Management Board was continuously continued and implemented. Corresponding changes to the Executive Board are explained in detail in the Governance section.

CONTACT PERSON FOR QUESTIONS ABOUT THE REPORT

If you have any questions about the sustainability report, please contact our sustainability team via the following e-mail:

sustainability@meleghyautomotive.de

UNSERE BETRACHTETEN ENTITÄTEN:

- » Meleghy Automotive Wilnsdorf, Germany
- » Meleghy Automotive Gera, Germany
- » Meleghy Automotive Lauter-Bernsbach, Germany
- » Meleghy Automotive Löbnitz, Germany
- » Meleghy Automotive Reinsdorf, Germany
- » Meleghy Automotive Abrera 1, Spain
- » Meleghy Automotive Abrera 2, Spain
- » Meleghy Automotive Brandys nad Labem, Czech Republic
- » Meleghy Automotive Miskolc, Hungary



GENERAL INFORMATION

Meleghy Automotive is a family-run company that has been developing innovative solutions for the automotive industry since 2012. With eight production sites in four countries and around 1,300 employees, the company has an international presence and achieved a turnover of around 350 million euros last year.

On a production area of 124,000 square meters, Meleghy Automotive processes over 100,000 tons of steel and 5,000 tons of aluminum annually - precisely, efficiently and sustainably.

Our mission: We shape more than metal - we shape the future. With expertise, innovative strength and team spirit, we develop solutions that go beyond the product and make a sustainable contribution to the mobility of tomorrow.

Our vision: We set new standards with precision, innovation and commitment - for a sustainable future.

As a responsible partner to the automotive industry, we combine technological excellence with ecological and social responsibility. By continuously optimizing our processes, using resource-saving technologies and pursuing a forward-looking corporate strategy, we are meeting the challenges of the future.

Our origin

Meleghy Automotive is rooted in the long tradition of the automotive supplier sector. The company was founded in 2012 through the acquisition of Neef Fertigungstechnik GmbH and the in-depth expertise of the founding families - a decisive step in building a strong and future-oriented corporate structure.

Through the targeted acquisition and integration of further companies at home and abroad, a regional family business developed into an internationally active company under the umbrella of Me-

leghy International. This strategic growth course laid the foundation for sustainable innovation and entrepreneurial development.

Today, the Meleghy Automotive brand unites all of the Group's production and administration sites. Our focus is on the development and production of high-precision structural components made of steel and aluminum - with the aim of offering the automotive industry sustainable and innovative solutions in sheet metal processing.

Our family business

As a family-run company, we focus on values such as solidarity, trust and tradition. Our success is based on cross-generational cooperation, a corporate culture based on partnership and the commitment of our employees.

Sustainability is not just an obligation, it is how we see ourselves as a company. Our philosophy goes beyond economic stability and innovative strength - we take responsibility for ecological and social aspects along the entire value chain.

Our standards:

**Shaping a sustainable future
- for present and future generations.**

Our core competencies

TECHNOLOGY-SUPPORTED SOLUTIONS - FROM DEVELOPMENT TO SERIES PRODUCTION

Meleghy Automotive is more than just a manufacturer - we are an innovative partner for the automotive and sheet metal processing industry. Our range of services covers the entire process chain: from the initial idea to development and series production.



Umformung



Fügetechnik



Beschichtung

Forming technology & Sheet metal working

High-precision production of structural components by deep drawing, punching and bending.

Innovative joining techniques

State-of-the-art processes such as spot welding, laser and MIG/MAG welding as well as mechanical joining techniques ensure long-lasting connections.

Surface coating & corrosion protection

Our KTL and powder coatings offer optimum protection and extend the service life of our components.

MiMEC® – Meleghy Innovative Method Engineering Center

With MiMEC® we optimize production processes and enable efficient series production of new technologies.

Our customers

- PARTNERSHIP FOR SUSTAINABLE SUCCESS

Meleghy Automotive is a reliable partner for international OEMs and Tier 1 suppliers. We offer customized solutions that meet the highest quality standards and support our customers along the entire process chain.

OUR PRINCIPLES

- » Trust & reliability - Long-standing, stable business relationships
- » Innovation through partnership - Joint development of new technologies
- » Quality leadership - Strict standards and continuous optimization
- » Sustainability - Efficient and resource-saving production

OUR CUSTOMERS AT A GLANCE

- » Leading automotive manufacturers and suppliers
- » Companies from the sheet metal processing industry

Our products and solutions

Meleghy Automotive develops and produces high-precision metal components and assemblies made of steel and aluminum for load-bearing vehicle structures. Our products meet the highest standards of safety, quality and efficiency.

PRODUCT PORTFOLIO

- » Structural components & assemblies for bodywork and superstructures
- » Chassis components to optimize stability and dynamics
- » Struts & stabilizing elements for safety and rigidity

Our components are made of steel and aluminum with thicknesses between 0.6 and 3 mm.

Examples of our products

- » Side members
- » Battery consoles
- » Rear end parts
- » A-pillars & cross members
- » Diagonal struts & dome struts
- » Tank tubes & bracing elements
- » MiMEC® Products

With state-of-the-art production technology and a high level of process expertise, we offer innovative solutions for the mobility of tomorrow.

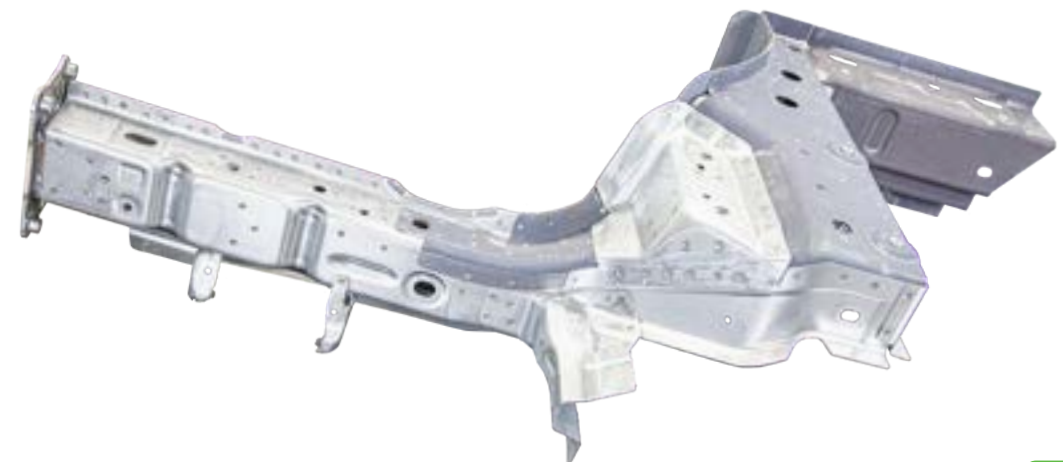
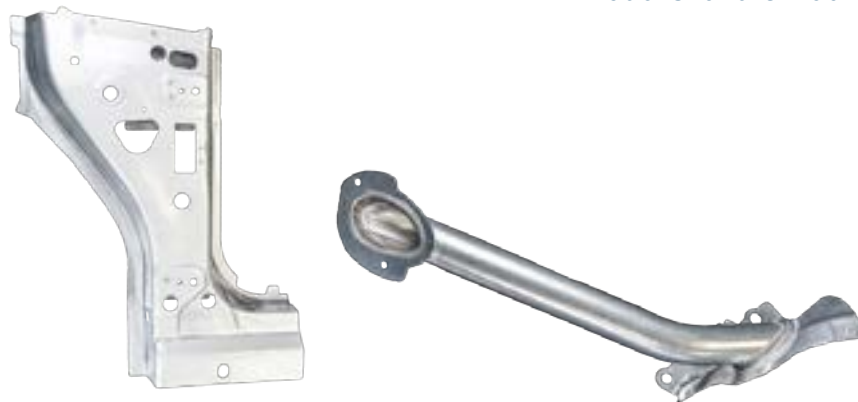
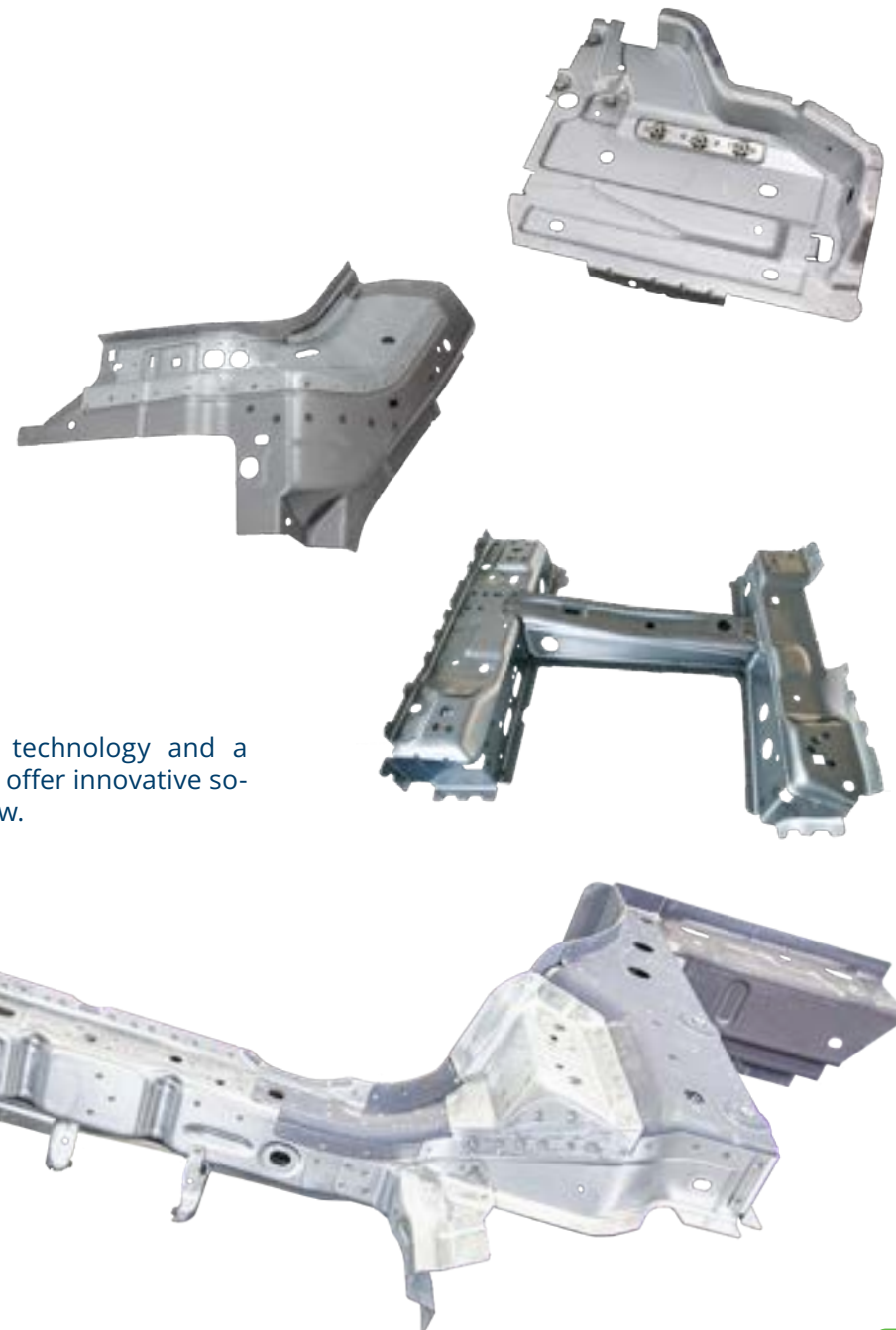

Our locations

Strategically positioned for maximum efficiency and customer proximity

Meleghy Automotive operates an international network with eight production sites in four countries. Our plants are specifically positioned to enable optimal logistics, fast response times and seamless co-operation with our customers. This global production network not only guarantees the highest quality and reliability, but also strengthens our competitiveness through short delivery routes and flexible capacities.



Location development 2024

In 2024, we started construction of our new plant in Miskolc, Hungary - a state-of-the-art production site that will expand our production capacities and strengthen our market presence in Central Europe. At the same time, we made a strategic decision to relocate production from our smallest production site in Löbnitz, Germany, to the Bernsbach plant and close the site. These measures will enable us to deploy our resources in an even more targeted manner and further increase our efficiency.

Germany

- » Gummersbach
- » Wilnsdorf
- » Gera
- » Reinsdorf
- » Bernsbach
- » Löbnitz

Spain

- » Abrera 1 (Barcelona)
- » Abrera 2 (Barcelona)

Czech Republic

- » Brandýs nad Labem (Prag)

Hungary

- » Miskolc



Some of our locations serve as centers for innovation and technology. Here, highly qualified teams work on pioneering solutions for the automotive industry. With state-of-the-art production technology and continuous process optimization, we are setting new standards in metal processing.

Our philosophy

FORMING TOMORROW FOR YOU. FOR US. FOR EVERYONE.

Technological excellence and corporate responsibility go hand in hand at Meleghy Automotive. Our goal is not only to be economically successful, but also to actively shape a sustainable future. This characterizes our daily actions - from the development of innovative products to a value-oriented corporate culture based on cohesion, openness and commitment.

Our mission

- We form more than just metal

„We form more than metal-we shape the future. Driven by expertise and collaboration, we push boundaries to create solutions that matter and move the world forward.“

We shape the future of mobility - sustainably, innovatively and in partnership. Through our expertise and close collaboration, we create solutions that offer real added value and move the world forward.

Using state-of-the-art technology and efficient processes, we optimize products and production methods to combine ecological, economic and social responsibility.

Our vision

- Shaping the future with precision and innovation

„With precision, innovation, and dedication, we turn visions into reality for a better tomorrow.“

Our vision is clear: with precision, innovation and dedication, we turn visions into reality - for a better tomorrow.

We want to be the preferred partner for sustainable and technologically leading solutions and actively contribute to the further development of the automotive industry. Our aim is not just to follow trends, but to set global standards.

Our guiding principles

- Our foundation for sustainable action

Our guiding principles have been the foundation of our actions since 2012. They were developed together with our employees and are a central component of our corporate culture. They combine our mission and vision with daily decisions and enable us to consistently pursue our goal of a sustainable future. In a nutshell, they say:

- » Trust & cooperation - We focus on long-term partnerships and open communication.
- » Innovation & excellence - We question the status quo, think ahead and set new standards.
- » Sustainability & responsibility - We act with foresight and design solutions for future generations.
- » Quality & precision - We aim to meet the highest standards in everything we do.

Our stakeholder communication

At Meleghy Automotive, we rely on open and trusting communication with various stakeholders. We consider this to be a key factor in our sustainable business success. We take account of changes in legal and regulatory requirements. Below we list some of our stakeholders and the main communication channels:

Stakeholder	Selected communication methods
Management	Management and leadership meeting, employee magazine
Customers	Customer visits, meetings, trade fair appointments, audits
Employees	Company meetings, workshops, events, website, social media, employee magazine, round table
Suppliers and business partners	General terms and conditions, supplier self-disclosure, supplier audits, workshops audits, workshops, code of conduct, sustainability questionnaire
Authorities	Dialog, answering inquiries, statistical reports
Financial management	Talks, workshops, seminars and congresses, trade fairs
Associations	Bilateral and individual interviews, workshops, career fairs, open days

Our partners and suppliers

At Meleghy Automotive, our partners and suppliers are critical to our success and our commitment to sustainability. We foster long-term relationships based on shared values and goals and ensure that they meet our high standards in quality, sustainability and social responsibility. Our collaboration aims to ensure an efficient and ethical supply chain, develop innovative solutions and minimize environmental and social impact. These partnerships span the entire product life cycle and create added value for our customers and society.

OUR PURCHASING PROGRAM INCLUDES:

- » Raw materials: steel and aluminum as coils and blanks
- » Stamped, pressed and drawn parts: made of steel and aluminum, bent wire parts
- » Standard and connecting parts: welded and punched nuts, screws, turned parts, rivets, bolts
- » Contract work: Galvanizing, KTL and powder coating, lasering, polishing, blank cutting
- » Punching and forming tools: transfer, progressive die, test gauges
- » Joining systems: robot welding systems, devices
- » Capital goods: machinery, equipment, buildings
- » Non-production materials: energy, occupational safety, technical gases, welding materials, packaging, containers...

SECURING RAW MATERIALS AND MATERIALS

As a supplier, we follow the material and component specifications of our customers, which have been predefined by them. Changes require a proposal and the approval of our customers. Where possible, we examine the use of sustainable alternatives from an economic and ecological point of view. Ensuring security of supply is a decisive criterion in this process.

REQUIREMENTS FOR PARTNERS

The requirements for our suppliers and partners at Meleghy Automotive are defined by various international standards and the company's own guidelines. These form the basis for our partnership-based cooperation and include the following criteria:

- » Economic stability and reliability
- » Certified management systems
- » Quality standard IATF 16949, alternatively ISO 9001
- » Environmental standard ISO 14001
- » Energy standard ISO 50001
- » Consistent implementation of the zero-defect principle
- » Competitive price-performance ratio
- » Delivery reliability and adherence to delivery dates
- » Flexibility and high level of service
- » Willingness to optimize products and processes
- » Acceptance of our general terms and conditions of purchase



- » Compliance with the requirements of the German Supply Chain Duty of Care Act (LkSG)
- » Recognition of the Meleghy International Code of Conduct on social responsibility
- » Compliance with the law
- » Integrity and organizational governance
- » Consumer interests
- » Communication and financial responsibility
- » Information security
- » Protection of intellectual property and counterfeiting
- » Human rights and working conditions
- » Environmental protection and energy management (careful use of resources and waste avoidance)

This approach ensures our corporate responsibility and ensures that we do not enter into partnerships with organizations or partners that do not meet these standards.

In 2024, we also stepped up our activities to make our supply chain more sustainable and integrated the requirements of the LkSG into our procurement processes.

Our staff

The employee figures were collected as at 31.12.2024. All employees were included here, with the exception of temporary staff, trainees, interns and temporary workers.

The distribution of employees in the various plants in December 2024 shows that the proportion of female employees at all locations still has room for improvement compared to male employees. In total, there are 1,230 employees, of which 1,036 are men (84.2%) and 194 women (15.8%) Compared to the previous year, the proportion of women increased by 0.3%. The Brandys plant continues to have the highest proportion of women at 32%. This is followed by the Reinsdorf site with 17% and the Abrera and Gera sites with 15% and 14% respectively.

Furthermore, the principle applies that employment relationships are not limited in time, unless they are substitute employment relationships due to illness, parental leave or other substitutions or longer absences. Another reason for a fixed-term contract may be a foreseeably limited production period. A

fixed-term employment contract is therefore only concluded if it is foreseeable from the outset that there will be no vacancies afterwards.

In December 2024, the proportion of fixed-term contracts was 11.1%. At 4.3% and 4.0%, the Reinsdorf and Gera sites had the highest proportion of fixed-term contracts, Wilnsdorf 2.1% and Bernsbach 0.7%. The Abrera, Brandy's, Miskolc and PDE locations have no fixed-term employment contracts.

Of the 1,230 employees, 1,211 were employed full-time. This corresponds to 98.5% of all employees. At 84.9%, the percentage of male employees is significantly higher than the percentage of female employees at 15.1%.

19 employees worked part-time, which corresponds to 1.5% of all employees. Our part-time ratio fell by 2.0% compared to the previous year. At 58%, the proportion of female part-time employees was higher than the proportion of male employees at 42%. The individual distribution of total employees, as well as full-time and part-time employees, can be seen in the following diagrams. The breakdown is by plant and by gender.

We continue to strive to increase the proportion of women in the overall workforce, particularly in the production departments and production-related support areas. Our Brandy's site is a good example - with one third of the workforce, the site has a high proportion of women.

As in the previous year, we take part in official campaigns such as „Girls' Day“ to get girls interested in technical and scientific professions. Girls are also increasingly interested in the „Open Company Week“ campaign, in which school pupils can get to know different professions over the course of a week.

Our internship offers, which can be completed by pupils from the 7th grade onwards, continue to be popular. Through our presence at schools in the area, which we cover through the training managers and the HR department, we continue to try to draw attention to us and the associated range of women's activities.

We also carry out in-house measures at the individual locations to recruit female employees from the production areas for in-house training or further training in the technical field.

Employees* by gender in 2024

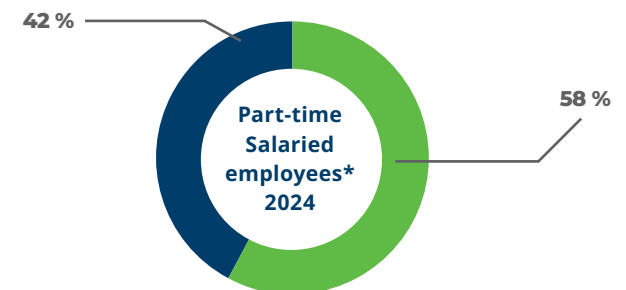
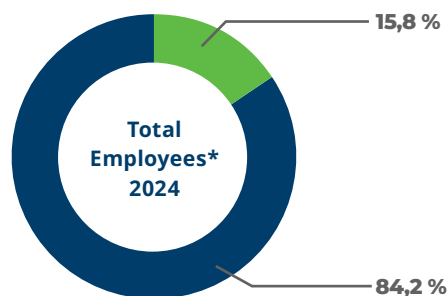

*excluding trainees, temporary staff, students, etc.

■ female ■ male

OUR OTHER EMPLOYEES

At the end of 2024, the company had a diverse workforce consisting of permanent employees, trainees, temporary staff, working students and temporary workers.

Temporary workers

At 134 people, temporary workers made up the largest group of non-permanent employees. They are mainly employed in production (simple helper activities) and logistics (goods movement activities). The need for temporary workers results primarily from seasonal and customer-related fluctuations in production volumes.

Our aim is to integrate temporary workers into our permanent staff if they are suitable and vacancies are available. Even today, vacant positions in the production area are preferentially assigned to long-serving temporary workers.

Temporary staff

Temporary staff support the company, particularly in the area of property maintenance. Their deployment is flexible and demand-oriented.

Apprentices

In December 2024, a total of 36 trainees were working at our locations. At the Bernsbach, Reinsdorf and Gera sites, a dedicated training manager is responsible for supervising and coordinating training.

At the Wilnsdorf site, trainees have access to a specially equipped area. In addition, the plants in Bernsbach, Reinsdorf and Gera have their own training workshops for technical and industrial training.

A special project is the training workshop at the Reinsdorf site, which was started in the third quarter of 2023 and is scheduled for completion in mid-2025. In future, the Reinsdorf training workshop will be used in particular for electrical engineering training.

Cross-site deployment of trainees is already common practice: for example, trainees from Bernsbach and Reinsdorf are deployed at both sites in order to make optimum use of the available training resources. Close coordination between the training managers - particularly between the Reinsdorf and Gera sites - ensures that training is efficient and practical.

DIVERSITY MANAGEMENT

Diversity and equal opportunities are key components of our sustainable corporate development. We promote a working environment in which all employees - regardless of gender, origin, age, religion, lifestyle or other personal characteristics - have equal development opportunities.

We see the heterogeneity of our workforce as an opportunity: it enriches our corporate culture, strengthens our innovative power and helps us to respond flexibly to the requirements of our markets.

In order to consistently rule out discrimination, harassment and disrespectful behavior, raising awareness among our employees is an integral part of onboarding. As part of the induction process, we explicitly familiarize all new employees with the principles of our Code of Conduct, which sets out clear rules for respectful and non-discriminatory interaction.

Employees who are not salaried employees (2024)

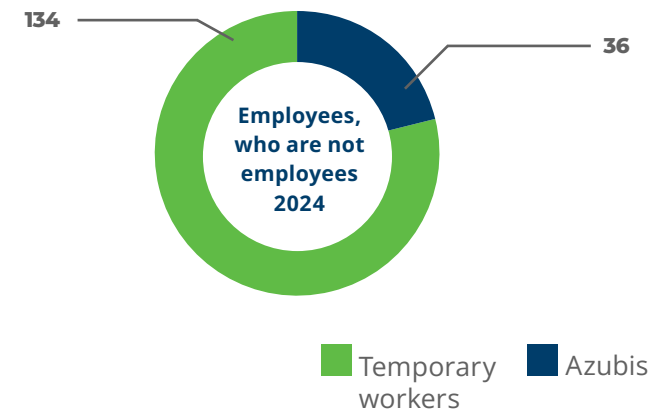

Our governance

Meleghy Automotive, a family-run company, attaches great importance to responsibility and ethical behavior. We comply with applicable laws and are committed to ethical standards in all our actions. Our understanding of responsibility for ecological, economic and social action is anchored in the Code of Conduct of our Meleghy International group of companies, which also applies to the Meleghy Automotive entities.

Our internal guiding principles complement this responsibility and illustrate our aspiration to conduct our business activities in a sustainable manner in harmony with our society, the environment and biodiversity for future generations.

RESPONSIBLE CORPORATE MANAGEMENT

Meleghy International is the brand name that stands for the entire group of companies without being a separate legal entity. Meleghy & Cie. Automotive GmbH is the sole shareholder of the operating companies that operate under the Meleghy Automotive brand.

Meleghy International is managed by a two-tier management system consisting of the group of shareholders and the management of the group of companies. These two bodies form the top management level of Meleghy International and act in accordance with the tasks and powers defined in the shareholders' agreement.

Meleghy Automotive - Entities are an integral part of Meleghy International and are subject to the direction of senior management.

The Management Board of Meleghy International is responsible for the overall management of the company and thus also of the entities relevant to reporting. In cooperation with the representatives of the operating units and the central functions, it forms the top management level. Communication and coordination take place on a regular basis through fixed meetings in which operational and service-related topics are discussed. Both short-term operational matters and long-term strategic decisions are made on this basis in order to ensure a coherent and coordinated approach at all management levels. Re-

sponsibilities are defined in the management organization chart.

CLEAR RESPONSIBILITIES FOR SUSTAINABILITY ISSUES

Clear guidelines for our sustainable actions on ecological, economic and social issues are anchored in our CoC. Compliance is a fundamental component of our business activities.

Our employees undertake to comply with the CoC and act in a legally compliant and responsible manner. We also have corresponding requirements and expectations of our partners, suppliers and customers.

The Executive Board is responsible for overseeing and ensuring compliance with the governance principles and for governance, risk and compliance (GRC). Operational implementation takes place within the Meleghy Automotive organization, which has set up its own GRC/CSR organization.

Our memberships

EXTRACT FROM OUR MEMBERSHIPS

Associations			
AWU Arbeitskreis Wilsdorfer Unternehmer	ACOD Automotive Cluster Ostdeutschland	Stiferverband der deutschen Wissenschaft	WIFU Wittener Institut für Familienunternehmen
IBU Industrieverband Blechumformung	AT Automobil Thüringen	TH Köln Technische Hochschule Köln	BPM Bundesverband der Personalmanager
VDA Verband der Automobilindustrie	Fraunhofer Gesellschaft	Smart3 e.V.	IHK/AHK Industrie und Handelskammer
Training facilities			
IHK/AHK Industrie und Handelskammer	TÜV Technischer Überwachungsverein	Haufe	IBU Industrieverband Blechumformung

Meleghy Automotive is a member of various associations and interest groups as well as external initiatives for economic, ecological and social improvements. The benefits of these memberships are manifold. They give us access to a valuable network of experts and companies. This facilitates the exchange of best practices, collaboration on solutions and access to the latest information and research findings, also in the context of sustainability. In this area in particular, we enlisted the support of the IBU in 2024 in order to meet the requirements of CSR. In the area of training skilled workers, we make use of the opportunities offered by internal and external training courses.

In our training workshops, we train both internally and externally in cooperation with the following institutions, among others:

- » Berufs- und Förderungswerk BFG Gera,
- » AWA Altenburg,
- » IB Jena,
- » OAV Ostthüringer Ausbildungsverbund,
- » Edelstahlwerke Siegen

Our economic performance

The 2024 financial year was characterized by far-reaching macroeconomic and geopolitical developments, which had a noticeable impact on the automotive industry and therefore also on Meleghy Automotive.

Supply chains, which had already been under strain in previous years, came under renewed pressure due to the ongoing war in Ukraine. At the same time, the expiry of government subsidies for electromobility led to a significant decline in the sales markets for electric and hybrid vehicles. Combined with persistently high inflation and the associated reluctance to buy on the part of customers, this resulted in a challenging market environment overall.

These factors had a noticeable impact on our sales performance in 2024. Despite high internal efficiency and stability in our processes, we recorded a decline in sales. Nevertheless, we are confident about the future: we expect the markets to stabilize in the medium to long term and that our investments in innovation, partnerships and sustainable production processes will have a positive impact on business development in the coming years.

Our goal remains to operate in a sustainable and crisis-proof manner - and to reconcile long-term growth with ecological and social responsibility.

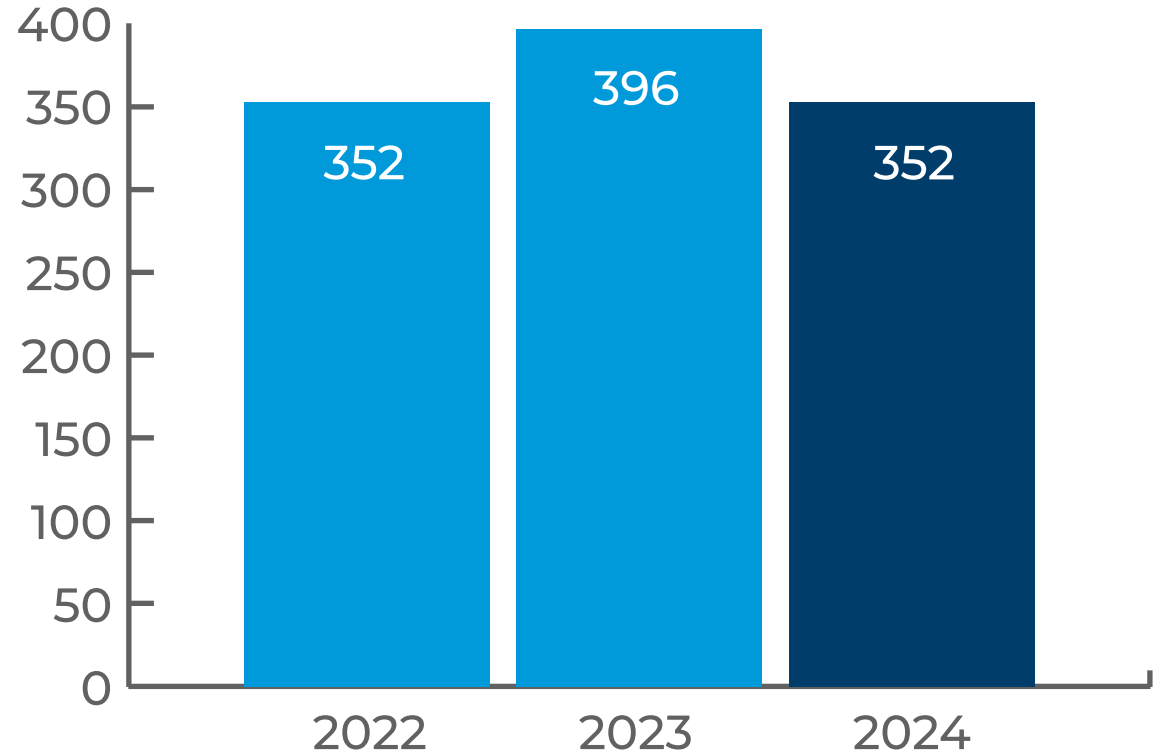

Turnover in million euros

Our innovations



One focus of our development activities is on reducing the consumption of resources through the use of mechanical joining technologies. In this context, we have developed and patented innovative process technologies under the registered trademark MiMEC.

MiMEC is continuously being developed and simulated using our own FEM methodology. MiMEC is used for material pairings of steel and aluminum.

In the area of production, we intensified our efforts to optimize the resistance spot welding of aluminium.

The aim is to increase the welding quality and service life of copper welding caps and reduce power consumption.

In the area of logistics, innovative forming technology, integrated into the body assembly production systems, helps to drastically reduce transport costs and thus save resources in the long term.

By using innovative 3D printing techniques, we have succeeded in using plastic replacement and wear parts for our equipment in a resource-efficient manner instead of elaborately mechanically manufactured steel parts.

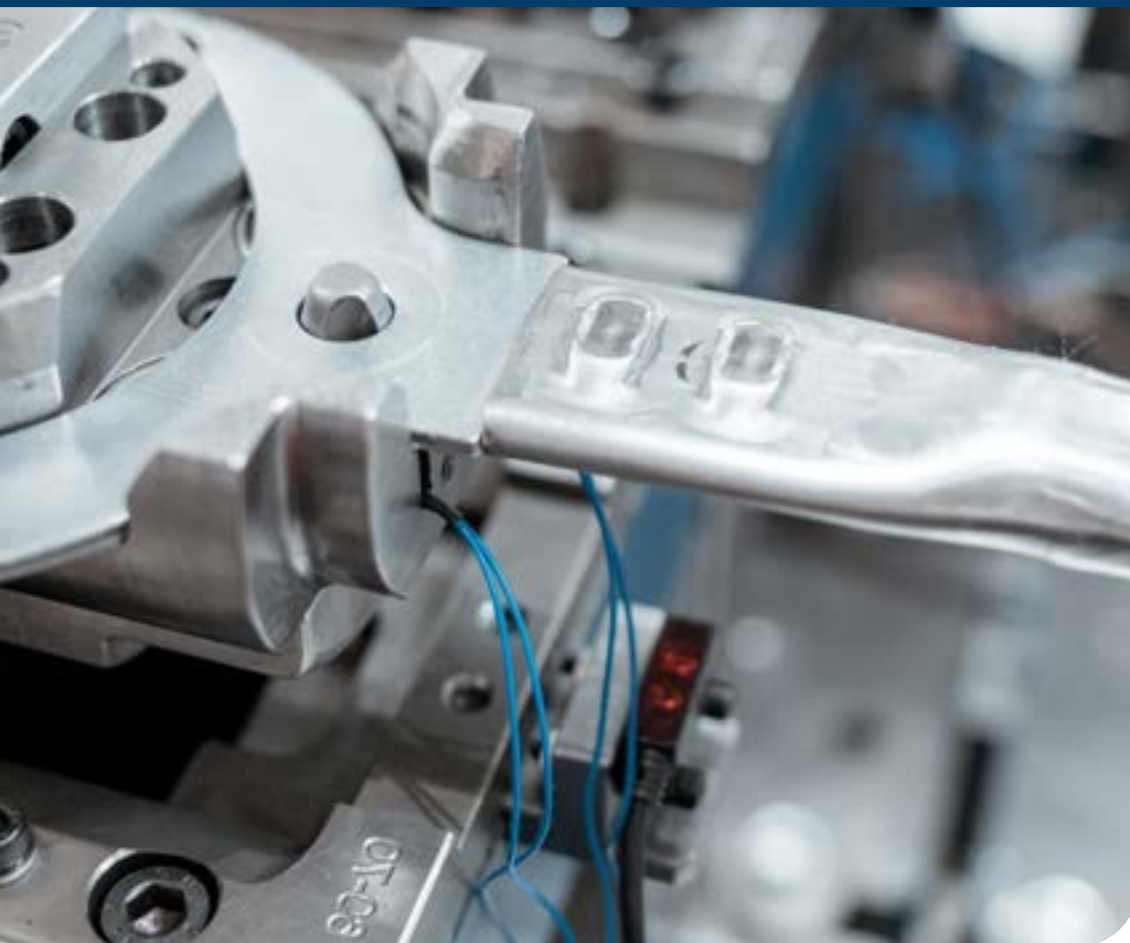



ETHICAL BUSINESS



I Agree

Our Code of Conduct

Meleghy International is committed to social responsibility in its business activities worldwide and has introduced and continuously developed a comprehensive Code of Conduct (CoC) within the Corporate Social Responsibility (CSR) guidelines.

The CoC contains fundamental principles and behavioral guidelines for our corporate activities and covers the areas of working conditions, social and environmental compatibility, information security, transparency and trusting cooperation both in internal operations and in stakeholder dialog. These guidelines are a reflection of our corporate values.

We take responsibility to consider the economic, technological, social and environmental impact of

our business decisions and actions. Meleghy International is voluntarily committed to the well-being and sustainable development of global society and is guided by universal ethical values and principles, in particular integrity, honesty and respect for human dignity. We expect all our stakeholders to uphold these values and to comply with them throughout the entire supply chain.

In order to continuously expand our CSR, the management regularly reviews and implements new initiatives. This includes measures for occupational health and safety, ethical business practices and social commitment at our sites. The full CoC is also available on our website.

The most important obligations in our CoC are:

- » Integrity is the basis of our actions.
- » Compliance with labor law regulations and the protection of human rights.
- » Transparent data and information management.
- » Holistic consideration of nature and biodiversity for future generations.
- » Ensuring that our employees have access to open and respectful communication.
- » Communicating with suppliers to ensure compliance with environmental requirements arising from new legislation (Supply Chain Sustainability Act LkSG)

Our compliance

Compliance with corporate values, codes of conduct and relevant laws, policies and standards is essential for Meleghy Automotive to minimize risks associated with corporate governance and business operations. We understand compliance risks to be the potential for violations of these principles and laws, which could potentially lead to loss of orders, loss of customers, damage to reputation, legal sanctions and/or financial consequences.

In the previous reporting period, Meleghy Automotive conducted a comprehensive compliance assessment on two levels. This assessment covered our operating sites as well as the corporate level of our company.

The probability of occurrence and the resulting impact of these factors on the company's business activities were assessed.

All business units and central departments were involved in this process, which covered the following topics:

- » Corruption Evaluation index (T1)
- » Conflicts of interest (T2)
- » Human rights (T3)
- » Labor standards (T4)
- » Compliance with the law (T5)
- » Occupational safety (T6)
- » Environmental laws (T7)
- » Money laundering, extortion (T8)
- » Fair competition, antitrust law (T9)

- » Protection of intellectual property, plagiarism (T10)
- » Use of private security services (T11)
- » Privacy (T12)
- » Harassment (T13)
- » Inclusive culture (T14)

As none of the compliance risks were rated red, the results of the survey paint a positive picture of the compliance status at Meleghy Automotive. This assessment is subject to an annual review and, if necessary, existing issues are reclassified, expanded

and supplemented as required. To this end, we review proposals for additional risk mitigation measures for all risk scenarios and strive to continuously improve our compliance practices.

We maintain a legal register in our organization, which is reviewed and updated at least once a year. When it comes to occupational safety, we make use of both internal and external support in the form of specialists. In addition, we review our HR-specific activities through our in-house counsel.

		Probability			
		unlikely	low	probably	high
Influence	extreme				
	large		T6	T8	
	moderate	T7 T9 T11	T1 T2		
	low	T4 T10 T12	T3 T5 T14	T13	



Our whistleblowing system

The policy on whistleblowing/ whistleblowing system of the Meleghy International Group, which came into force on October 1, 2023, was valid unchanged at all Meleghy Automotive locations in calendar year 2024.

On January 16, 2025, the individual reporting offices were asked to provide information regarding any reports of grievances/discrimination cases or reporting procedures to be carried out in this respect for the year 2024 with a deadline of January 21, 2025. The information from the reporting offices at the locations in the Czech Republic, Spain and Hungary was provided by 20.01.2025. The feedback showed that no incidents were reported at these locations in 2024 and therefore no reporting procedures had to be carried out.

Two matters requiring investigation were reported

at the German sites and processed by the undersigned as part of a reporting procedure.

The first report was made on November 6, 2024 and related to the suspicion of bullying. In the course of investigating the facts of the case, no sufficient evidence of bullying was found. The reporting procedure was concluded on 27.11.2024 with the preparation of a final report and information to the parties involved in the proceedings.

The second notification was made on 29/11/2024 and related to the suspected unjustified deduction of an employee's pay as part of the July 2024 payroll. The legal basis for the deduction of pay was explained to the complainant by the Head of HR and the undersigned at a hearing on 04/12/2024. The proceedings were discontinued on 20.01.2025 by means of a final notification to the complainant.



Our information security and data protection management system

Customers and their protection are at the heart of our management systems. As proof of our compliance with information security requirements, we carry out regular internal audits and have the TISAX® label (Trusted Information Security Assessment Exchange) confirmed by an external auditor every three years. The rules and regulations are currently being revised and, in particular, prepared for the new VDA ISA catalog version 6 for the upcoming audit in 2025. The regulations not only serve to protect IT, but also personnel security, building security, supply chain security and the protection of machine-

ry and equipment. To further develop our processes and methods in the area of information security, an external information security officer was appointed, who uses his expertise to develop and implement new requirements, e.g. in the area of crisis management with the update to ISA catalog version 6, for Meleghy.

Merging the management systems, also in combination with quality management, serves not only to reduce costs, but also to increase resilience to business-critical events.

A photograph of an industrial factory floor. Several orange KUKA robotic arms are visible, some holding large, white, bag-like components. The background shows a complex network of metal structures and overhead lighting.

**ECONOMIC AND ECOLOGICAL
SUSTAINABILITY**

Our materials and waste management

Meleghy Automotive has a strong focus on the responsible use of materials and waste management. Our products are mainly made of recyclable steel and aluminum. Steel in the automotive industry is approaching a closed-loop economy, as around 90% of the steel used in the industry worldwide is recovered. This helps to improve the environmental footprint, as recycled steel does not compromise on quality.

To avoid mixed waste, our plants are equipped to separate steel and aluminum materials. Compared to 2023, our procurement volume of steel and aluminum has fallen from 112,011 tons to 92,544 tons.

As part of the requirements of DIN EN ISO 14001 for environmental management, Meleghy Automotive continuously records waste generated, prepares an annual waste balance sheet and assesses the impact on our sites. We have developed and implemented a waste concept for all plants, including regular

checks of the waste disposal companies to ensure that they are authorized to dispose of the respective waste. The quantities of waste are categorized and documented in accordance with the current „Ordinance on the European Waste Catalogue (Waste Catalogue Ordinance - AVV)“. We feed paper, wood and film into the external recycling cycle, thereby reducing resource consumption and negative climate impacts. However, Meleghy Automotive products are mainly made of recyclable steel and aluminum. Repeatable recyclability results in an improved life cycle assessment.

As part of production process development and optimization, we attach great importance to keeping the material usage rate as low as possible and also to designing the production processes to be as robust as possible so that as little waste as possible is produced. We continuously monitor the reject rates and make adjustments in the event of deviations.



Our energy and water consumption

We have successfully implemented certified environmental management systems in accordance with DIN EN ISO 14001 at all Meleghy Automotive plants. In addition, our German plants are also certified in accordance with DIN EN ISO 50001 for energy management. This enables us to continuously record consumption values for electricity, gas and water over many years, which forms the basis for targeted optimization measures. We go one step further by systematically recording and evaluating consumption data not only for conventional fuels such as diesel and petrol (including industrial trucks), but also for the electricity required to charge our electric vehicles. This is particularly relevant as we increasingly

switch to electromobility and enables us to take efficient measures to reduce our energy consumption and promote sustainable mobility.

In 2024, 67% of total energy consumption was accounted for by electricity, 29% by natural gas and 4% by other fossil fuels. Compared to 2023, we were able to reduce the share of natural gas by a further 3% and halve the share of fossil fuels. This reduction underlines our commitment to a sustainable energy supply and our efforts to minimize our environmental footprint. We are implementing a comprehensive approach to continuously optimize our resource consumption. This includes the establish-

ment of a specialized energy and environmental team and the continuous training of our employees in these areas. We are also optimizing our energy monitoring in order to record and control consumption more precisely. A key aspect of our efforts is identifying best practice approaches and examining the possibility of implementing these across all plants. This enables us to use proven processes and solutions effectively and achieve our sustainability goals.

In 2024, we once again implemented extensive measures to reduce our gas consumption. With heat recovery, we were able to drastically reduce the operating costs of the compressors and save a lot of money. This is because a large proportion of the energy used to generate compressed air is converted into compression heat, which can be reused.

The reduction in fossil fuels is due to the switch from gas-powered trucks to electric ones.

RESPONSIBLE USE OF WATER

In the 2024 reporting year, the water consumption of the Meleghy Automotive production sites under review amounted to 31,130 m3. We were able to record a reduction in water consumption of 0.14% compared to the previous year.

	2021	2022	2023	2024
Electricity	25.075 53 %	25.341 60 %	25.162 60 %	29.469 67 %
Natural gas	17.984 38 %	13.680 32 %	13.267 32 %	12.920 29 %
Other	3.837 8 %	3.245 8 %	3.332 8 %	1.614 4 %

Implementation plan for energy management 2024/2025 in accordance with Section 9 EnEfG

Meleghy Automotive fulfills the legal obligation according to § 9 EnEfG to publish an implementation plan for economically evaluated energy saving measures. This is based on the results of the company’s internal energy management system in accordance with the requirements of DIN EN 17463 (VALERI).

more than 2.5 GWh per year, the identified measures were assessed in terms of their cost-effectiveness and summarized in a specific action plan for the years 2024/2025.

The implementation plan is part of our sustainability report and underlines our ongoing commitment to energy efficiency and resource conservation.

As a company with an average total final energy consumption of

Plant	Priority	Description	Investitions-volumen	Time frame	Origin of the measure	Responsible	Status
All plants	2025-07	Hazardous substance management: introduction of the Reca system - Automated procurement / removal	300€/month/closet	2025	Audit report 2024	Plant management	in progress
Wilnsdorf	2025-11	Replace radiator P69 (less energy and refrigerant) with new radiator	none	2025	Plant action plan	Head of Engineering	done
Gera	2024-03	Replacement of low budget hall lighting LED cold hall	24.000 €	2024	Plant action plan	Head of Maintenance	done
Gera	2024-04	Savings in hydraulic oil consumption GP05	none	2024	CIP	Head of Maintenance	done
Gera	2024-05	Waste heat utilization Compressors for the pressing plant	25.373 €	2024	Plant action plan	Head of Maintenance	done
Gera	2025-01	Replacement of compressed air refrigeration dryer / control system in forming area	102.883 €	2024	Plant action plan	Head of Maintenance	done
Gera	2025-02	Replacement of lighting in open-plan office, Gera room, Wilnsdorf room, break room, ENG office	Request for quotation	2024	Plant action plan	Head of Maintenance	in progress
Gera	2025-03	Replacement of lighting trades 2-5	38.410 €	2025	Rule meeting E/E	Head of Maintenance	in progress
Reinsdorf	2024-08	Photovoltaics	410.000 €	2024	Business plan	Head of Engineering	done
Reinsdorf	2025-01	Photovoltaic expansion 2nd stage	740.000 €	2024	Business plan	Head of Engineering	in progress
Reinsdorf	2025-02	Building extension / Move Relocation / GLT extension	1.600.000 €	2025	Business plan	Project team	done
Bernsbach	2024-03	Reduce pressure band by 0.5 bar	none	2024	Plant action plan	Head of Maintenance	done
Bernsbach	2024-06	Refurbishment of 3rd floor meeting room - replacement of lamps	<2000€	2024	Plant action plan	Head of Maintenance	done
Bernsbach	2025-04	2,000t servo press from Schuler, type TST4-2000-6	7.846.768 €	2025	Business plan	Plant management	done
Bernsbach	2025-05	Lighting press shop - control cabinet platform, and behind the old press (2-8)	1.335 €	2025	Plant action plan	Head of Maintenance	done

Our greenhouse gas emissions

Meleghy Automotive is firmly committed to continuously reducing our company's greenhouse gas emissions. Our efforts to sustainably reduce our carbon footprint include the following objectives:

- » Reduction of energy consumption
- » Procurement/generation of green electricity
- » Adaptation and introduction of low-emission or carbon dioxide-free technologies
- » Conversion from natural gas to renewable energies

In 2024, we included welding gases and coolants/refrigerants in the calculation for the first time. Group-wide, these categories have a significant impact of 666to. CO₂, these categories have a significant impact of 18.1% on total Scope 1 emissions.

Adjusted for this influence on the total emissions calculated for 2024, we were 1007to. CO₂ below the previous year's level. In addition to the gradual shutdown of production at the Lößnitz site, this is due to lower electricity procurement overall. This is due to the comparatively lower economic output.

To reduce CO₂ emissions, we will continue to work on increasing the proportion of renewable energies in addition to implementing energy-saving projects.

Direct emissions (Scope 1)

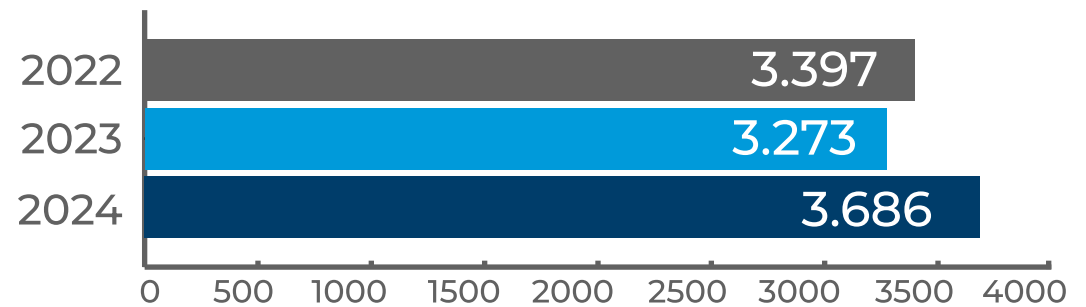

Indirect emissions (Scope 2)

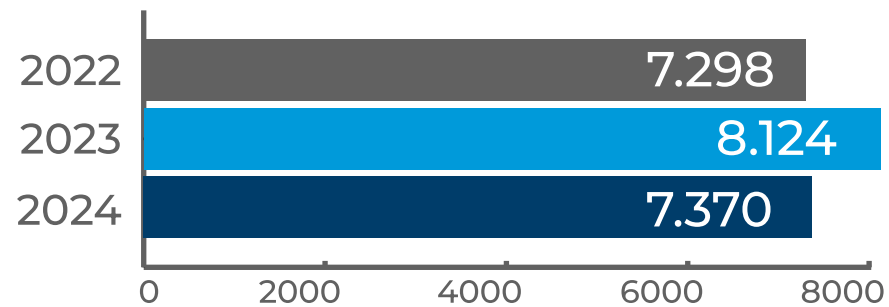

Total (Scope 1+2)

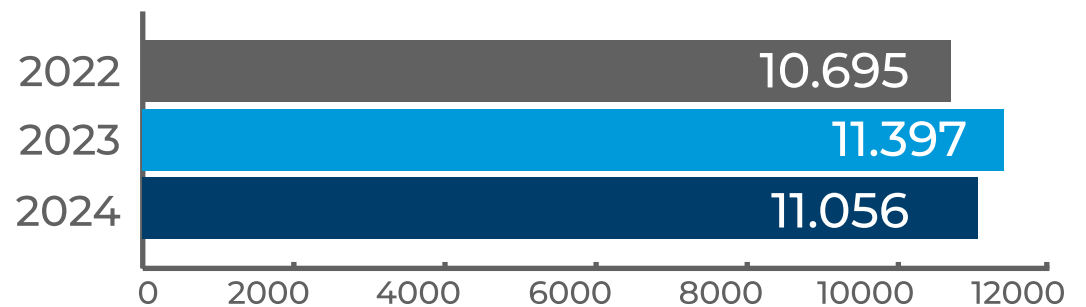

Our fleet management

Since 2019, we have been systematically implementing a mobility concept developed by our own mobility managers. The main objective of this concept is the gradual conversion of all company vehicles to electric mobility, including the necessary charging infrastructure. Meleghy Automotive will have a total of 24 charging points by 2024. These measures are part of our commitment to sustainable mobility and the reduction of our CO₂ emissions.

CONVERSION OF MOBILE COMBUSTION UNITS

To further reduce our CO₂ footprint, we are increasingly focusing on converting our mobile combustion units to electromobility. This applies not only to our fleet of vehicles, but also to our industrial trucks for internal transportation. We are proud to announce that the proportion of kilometers driven electrically in total mileage has increased from 0% in 2019 to 38% in 2024. This trend will continue as more petrol and diesel vehicles are converted and hybrid vehicles are replaced by fully electric ones. These conversion measures have enabled us to reduce CO₂ emissions per 1000 kilometers driven from an average of 0.194 tons in 2019 to 0.134 tons in 2024. This corresponds to an impressive 31% reduction in CO₂ emissions and is a further step towards making our fleet emissions climate-neutral.

Development of fleet emissions

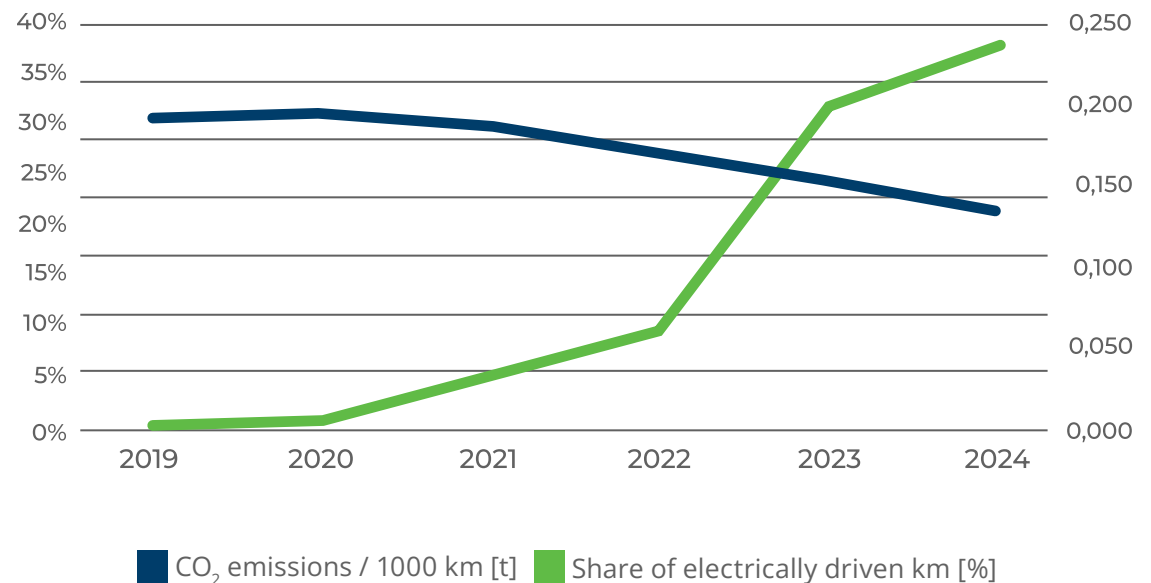

Since 2020, we have started to carry out research projects and apply for patents that are funded as tax and public research and development projects. We have received the necessary certifications for several projects that allow us to benefit from these grants.

In 2023, we received the research and development seal of approval from the Bescheinigungsstelle Forschungszulage (BSFZ).

This underlines our efforts and successes in the area of research and development as well as our commitment to innovative solutions.



Extract from our R&D activities





SOCIAL SUSTAINABILITY

Our health and occupational safety

We use a system that ensures the health and safety of all employees, regardless of whether they are employees or non-employees, i.e. temporary workers are also included in this system.

The system is based on official and legal requirements. All areas of the company are primarily monitored by the company safety officer and the plant manager at the site. The respective department heads also have access to their department so that all health and safety issues, such as risk assessments, accidents at work, etc., can be addressed and processed in one system.

An occupational health service has also been commissioned for all plants. The occupational health service commissions and carries out mandatory, optional and preventive examinations.

A quarterly occupational safety committee involving the safety specialist, occupational health service, plant management, plant management team, works council representatives and safety officers ensures compliance with and further development of the internal health and safety system.

HAZARD IDENTIFICATION, RISK ASSESSMENT AND INCIDENT INVESTIGATION

A risk assessment is available for each workplace, which describes the specific hazards and prescribes protective measures. It is drawn up for every new workplace. Every change to the workplace makes it necessary to revise the risk assessment. The assessment is carried out in particular in accordance with the requirements of the Occupational Health and Safety Act and the Workplace Ordinance as well as in compliance with other legal requirements.

As part of the risk assessment for each workplace, hazards, the risk of injuries and health impairments are identified and protective measures are defined.

A company agreement on the subject of risk assessment ensures that the works councils are extensively involved in the preparation of the risk assessment and, in particular, in the definition of necessary protective measures.

The procedure for identifying risks and investigating work-related accidents and incidents is described in

the works agreement „Risk assessment“. A joint investigation committee of works council and employer representatives investigates accidents, risk areas and incidents and develops corrective measures and preventive protective measures to avoid future risks.

The risk assessments are prepared and defined by the safety specialist and the respective department manager. Changes to the workplace and amendments to the Occupational Health and Safety Act and/or the Workplace Ordinance are updated regularly.

OCCUPATIONAL HEALTH SERVICE

The occupational health service can be used by any employee if they have or are suspected of having health problems as a result of their work.

If necessary, employees are invited to mandatory examinations. In addition, the examinations specified in the risk assessment are offered.

All information provided to the company doctor is

>>

subject to medical confidentiality. Personal data of employees within the scope of the occupational medical examination is stored by the doctor separately from the company data. Only the information on fitness for a specific job in the form of „suitable / temporarily not suitable / not suitable“ is communicated to the employer.

Prior to the meeting of the occupational safety committee, the company doctor carries out an inspection of the plant together with the safety specialist. The occupational safety committee meets quarterly. Accordingly, the internal system is regularly involved in identifying and eliminating risks and hazards.

The following overview shows the mandatory preventive examinations at the German sites. The corresponding employee allocation to the individual examinations is regularly checked and registered by the HR department in consultation with the company doctor, the safety officer and the respective department head.

G-examination	Meaning	certain conditions	Follow-up examination
G 20	Noise	if the action value for noise is reached or exceeded	36-60 months
G 24	Skin diseases	during wet work, skin contact with chemical substances	9 - 24 months, but after 60 months at the latest
G 25	Driving, control and monitoring activities		24 - 60 months
G 37	Computer workstation	when working with display screen devices	Under 40 years every 5 years, over 40 years every 3 years
G 37 DIN473	Near vision		
G 41	Working with fall hazards		12 - 36 months



Our training and further education

According to internal estimates, 2 days / 16 hours per year and employee are spent on training and further education. In-house training, short courses, etc. have not yet been systematically recorded.

The recording of this key figure is being prepared for 2024. It can be reported for the first time in the 2025 reporting year.

Qualification matrix

A skills matrix is used to check the skills of employees. In this matrix, the required qualifications and skills are compared with the individual quali-

cations and skills available. Deviations from the target profile lead to the training of necessary content.

Management development

The development of our managers continues to be very important to us. Management training will therefore continue to be offered and carried out. The new mission statement created in 2023 and the associated management principles are lived and integrated by our management team. Additional, individual management training courses are offered and held at the individual locations. The further development of our managers ensures that we as a compa-

ny have the necessary skills to lead our employees.

We also use a performance appraisal system that provides for an annual and, if necessary, half-yearly performance review between the line manager and employee.

The system is used to assess work performance and evaluate the agreed annual targets. Qualification and development measures are also defined for the coming year. On this basis, the individual training requirements are determined and anchored in the training plan for the following year.

An excerpt from our social commitment

JOB ADVERTISEMENTS AT YOURFIRM

At Yourfirm, we plant a tree for every job advertisement purchased. In this way, we want to actively protect the environment and make a sustainable contribution.

PROJECTS

Our Gera site participates in various initiatives, including the TIP (Day in Practice) and GAIT (Healthy Working in Thuringia) programs. The company is also active in the IHK-Schülercollege. In addition, Gera is involved in the „Unternehmen integrieren Flüchtlinge“ („Companies integrate refugees“) network to offer them active support and the chance to integrate into everyday life and have a successful future.

FAMILY FESTIVAL IN REINSDORF AND WILNSDORF

In the summer, both locations held a summer party. The party was a great opportunity for all employees and their families to spend some quality time together, catch up and enjoy the summer. We are plea-

sed that we can also strengthen team cohesion in this way.

DONATIONS FROM ALL LOCATIONS

Every year, our locations make donations to social institutions in their respective areas. In 2024, the Bernsbach, Reinsdorf and Gera locations once again supported the local soccer teams. In addition, the daycare centers receive a small donation every year, as the little ones are particularly close to our hearts. At the end of the day, we as a company transfer the daily wages of the two schoolgirls to the “genial-sozial” account.

REGIONAL TRAINING

The Wilnsdorf site is actively involved in the working group to promote training in the region. The focus here is on cooperation with schools, the organization of career exploration days and the provision of internships. The aim is to give young people practical insights into various professional fields and to strengthen regional training in the long term.















STAFF FUND

The Wilnsdorf site also has an employee fund that offers employees support on special occasions. These benefits include, for example, financial support for the birth of children, marriages and deaths. With the employee fund, we want to support our employees in important life situations in a spirit of solidarity.





















































An aerial photograph showing a dark asphalt road that curves through a dense, lush green forest. A white car is parked on the shoulder of the road. The road curves around a small pond or lake. The overall scene is serene and natural.

GRI CONTENT INDEX

GRI CONTENT INDEX

GRI-Index	Details	UN - 17 SDGs	Disclosure	Page
GRI2	General information 2021		2-1 Organizational details	6-7, 11
			2-2 Entities included in the organization's sustainability reporting	5, 9
			2-3 Reporting period, frequency and contact point	4, 5
			2-4 Correction or restatement of information	5
			2-6 Activities, value chain and other business relationships	8, 9, 13
		 	2-7 Employees	14, 15
		 	2-9 Governance structure and composition	3, 7, 16
		 	2-10 Nomination and selection of the highest governance body	16
			2-11 Chair of the highest governance body	16
			2-12 Role of the highest governance body in overseeing the management of impacts	16
			2-13 Delegation of responsibility for managing impacts	16
			2-14 Role of the highest governance body in sustainability reporting	16
			2-15 Conflicts of interest	16
			2-16 Transmission of critical concerns	24
			2-17 Collective knowledge of the highest governance body	16
			2-22 Statement on sustainable development strategy	3
			2-23 Policy commitments	22-24
			2-24 Embedding policy commitments	22-24
			2-25 Processes to remediate negative impacts	22-24
			2-26 Mechanisms for seeking advice and raising concerns	22-24
			2-27 Compliance with laws and regulations	23
			2-28 Membership associations	18
			2-29 Approach to stakeholder engagement	12
			3-1 Transmission of critical concerns	17

GRI Content Index

GRI-Index	Details	UN - 17 SDGs	Disclosure	Page
			3-2 List of key topics	17
			3-3 Management of key topics	17
200	Economic data			
GRI 201:	Economic performance 2016	 	201-1 Direct economic value generated and distributed	19, 20, 31
		 	201-4 Financial support from the public sector	31
GRI 204:	Procurement practices 2016	 	204-1 Proportion of spending on local suppliers	13
GRI 205:	Anti-corruption 2016		205-1 Operations assessed for risks related to corruption	22, 23
			205-2 Communication and training about anti-corruption policies and procedures	22, 23
			205-3 Confirmed incidents of corruption and actions taken	22, 23
300	Ecological information			
GRI 301	Materials 2016	   	301-1 Materials used by weight or volume	27
GRI 302:	Energy 2016	   	302-1 Energy consumption within the organization	28
		   	302-3 Energy intensity	28
		   	302-4 Reduction of energy consumption	28 / 29
GRI 303:	Water and wastewater 2018	 	303-1 Interactions with water as a shared resource	28
			303-5 Water consumption	28
GRI 305:	Emissionen 2016	    	305-1 Direct (Scope 1) GHG emissions	30, 31
		    	305-2 Energy indirect (Scope 2) GHG emissions	30, 31
		   	305-4 GHG emissions intensity	30, 31
		   	305-5 Reduction of GHG emissions	30, 31
GRI 306	Waste 2020	 	306-1 Waste generated and significant waste-related impacts	27
		 	306-2 Management of significant waste-related impacts	27
		 	306-3 Waste produced	27

GRI Content Index

GRI-Index	Details	UN - 17 SDGs	Disclosure	Page
GRI 308:	Evaluation of suppliers with regard to ecological aspects 2016		308-1 New suppliers that have been screened using environmental criteria	13
			308-2 Negative environmental impacts in the supply chain and measures taken	13
400	Social and societal data			
GRI 403:	Occupational health and safety 2018		403-1 Occupational health and safety management system	34
			403-2 Hazard identification, risk assessment, and incident investigation	34
			403-3 Occupational health services	35
		   	403-9 Work-related injuries	35
GRI 404:	Training and further education 2016	   	404-1 Average hours of training per year per employee	36
			404-2 Programs for upgrading employee skills and transition assistance programs	36
		  	404-3 Percentage of employees receiving regular performance and career development reviews	36
GRI 413:	Local communities 2016		413-1 Operations with local community engagement, impact assessments, and development programs	37
GRI 414:	Social assessment of suppliers 2016		414-1 New suppliers that have been screened using social criteria	13
			414-2 Negative social impacts in the supply chain	13
GRI 418:	Protection of the customer's privacy 2016		418-1 Substantiated complaints regarding the breach of protection and loss of customer data	25

The 17 UN Sustainable Development Goals



LEGAL NOTICE

PUBLISHER:

Meleghy & Cie. Automotive GmbH
Im Greuel 11, 51465 Bergisch Gladbach

Vertreten durch:
Dr. Gyula Meleghy (CEO)

EDITING AND DESIGN:

Sustainability-Team,
Abteilung Marketing
Meleghy Automotive

PICTURE CREDITS

Meleghy Automotive,
Goldbeck, Pixabay.com, Standort-Karte: Freepik.com

© 2024

Meleghy & Cie. Automotive GmbH
Im Greuel 11, 51465 Bergisch Gladbach

Email:
sustainability@meleghyautomotive.de

www.meleghyautomotive.de

